

Hydraulic and
Electronic Devices
Special Plug Connections

Pressure equalisation element DAEx

Technical Specifications

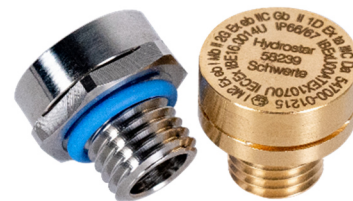

General Information

Air exchange in sealed housing with explosion protection application? No Problem!
Our pressure equalisation elements (formerly Gothe & Co. GmbH) have proven themselves reliably worldwide.

High temperatures and adverse environmental influences provide continuous pressure fluctuations in sealed housings - protect your sensitive electronics and improve the lifetime of electronic devices with our pressure equalisation elements.

- ⚡ For Ex - Applications (ATEX and IECEx)
- ⚡ Reliable reduction of condensate formation
- ⚡ Protection of harmful fluids and particles

Special Features

- ⚡ Flat construction
- ⚡ Easy installation (from inside or outside)
- ⚡ Very robust
- ⚡ Diverse versions
- ⚡ Air passage of up to 400 ml/min



Pressure equalisation element DAEx

Technical specifications



Technical Data

- ⚡ **Mounting body/cap** brass (optional nickel-plated, chrome-plated or stainless steel)
- ⚡ **Membrane** ePTFE (oleophobic)
- ⚡ **O-Ring** EPDM (optional FKM or silicone)
- ⚡ **Protection class** DIN EN 60529 IP66, IP67 (installed)
- ⚡ **Acceptable temperatures** - 20 °C ... + 80 °C (- 40°C ... +80°C usage of silicone O-Ring)
- ⚡ **Membrane Features** hydro- and oleophobic, wetting protection by surface tension $\geq 25\text{mN/m}$
- ⚡ **EC type-examination certificate** IBExU00ATEX1070 U
- ⚡ **IECEX - certificate** IECEX IBE 16.0014U

Operating principle

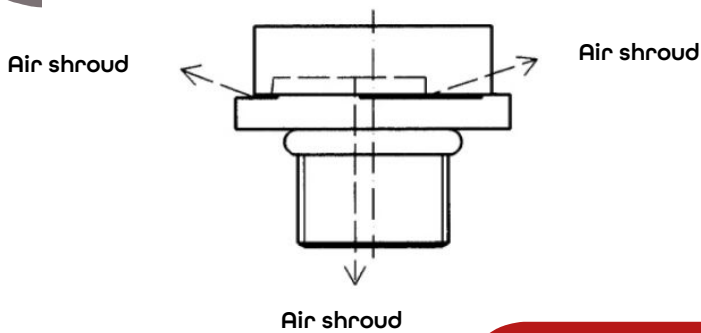

Ignition protection types:

-  I M2 Ex eb I Mb
-  II 2G Ex eb IIC Gb
-  II 1D Ex ta IIC Da

Manufactured sizes

⚡ Thread size	⚡ Air flow ($d_p = 70 \text{ mbar}$)	⚡ SW (external hex/hexagon socket)
M12 x 1,5	65 ml/min	19 mm/ 8mm
M16 x 1,5	80 ml/min	24 mm/ 8mm
M20 x 1,5	160 ml/min	27 mm/ 12mm
M27 x 1,5	400 ml/min	36 mm/ 19mm

Additional Pg or pipe thread available.



Pressure equalisation element DAEx

Technical specifications



Dimensions DAEx-AS (picture DAEx-AS-1215 on a scale of 2:1)

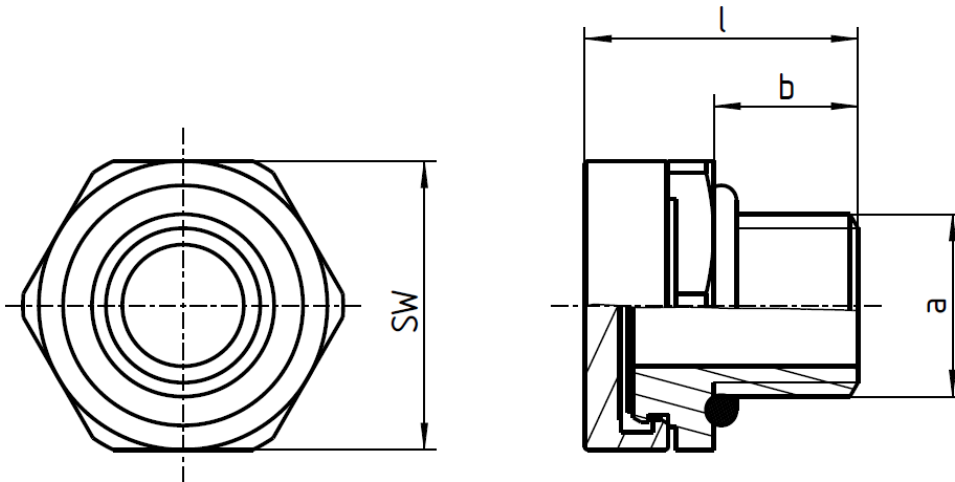

Artikel	a	b	l	SW
DAEx-AS/1215	M12x1,5	9,5	18	19
DAEx-AS/1615	M16x1,5	12	20,5	24
DAEx-AS/2015	M20x1,5	12	21	27
DAEx-AS/2715	M27x1,5	15	24	36



Pressure equalisation element DAEx

Technical specifications



Dimensions DAEx-IS (picture DAEx-IS-1215 on a scale of 2:1)

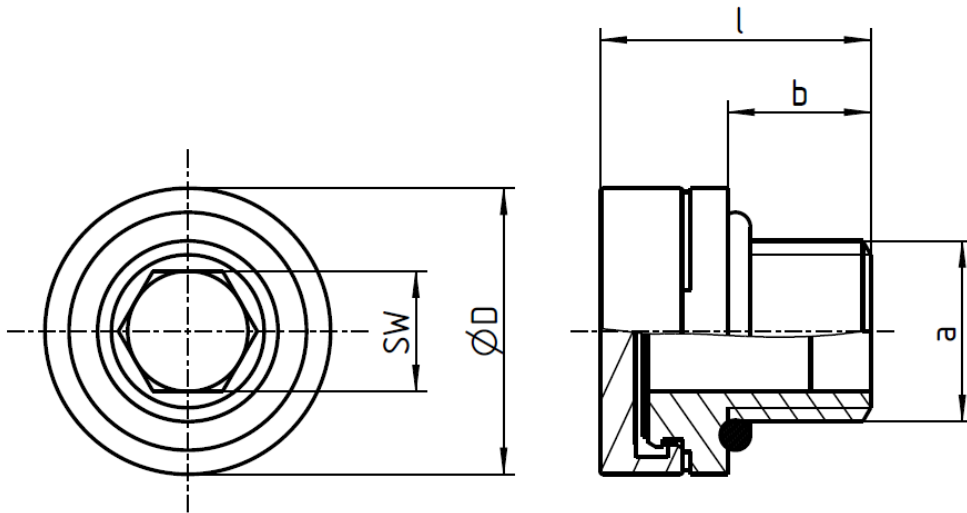

Artikel	a	b	l	SW	D
DAEx-IS/1215	M12x1,5	9,5	18	8	19
DAEx-IS/1615	M16x1,5	12	20,5	8	24
DAEx-IS/2015	M20x1,5	12	21	12	27
DAEx-IS/2715	M27x1,5	15	24	19	36



Pressure equalisation element DAEx

Technical specifications



Order Information

Basic type DAEx

DAEx

-

-

-

-

Mounting type

AS = External hex

IS = Hexagon socket

Thread size

1215 = M12 x 1,5

1615 = M16 x 1,5

2015 = M20 x 1,5

2715 = M27 x 1,5

Material mounting body and cap

MS = Brass

NI = Brass nickel-plated

CR = Brass chrome-plated

VA = Stainless steel

Material O-Ring

EP = EPDM

FK = FKM-sealing

SI = Silicone

